

PRELIMINARY



OXYGEN 4 DIGITAL DIGITAL MIXING CONSOLE

Internal digital bus routing system

Less than 0,5 milliseconds global latency

24bit/96kHz maximum sample resolution

EQ and Dynamics on all processing channels

Real time info displayed on every module

TCP/IP Ethernet / CobraNet Network operation

GPIO I/O automation - Fader, Switch, Cue start

Sample rate converters on all digital inputs

Built-in SD card reader

APPLICATIONS:

- Digital Desktop mixer
- Reporter desk
- Small edit suites
- Remote controllable audio work places
- Mobile applications

Oxygen 4 Digital is a fully digital mixing console powered by the latest Texas Instruments DSP processors, with 18 digital and analogue inputs, a cross-point router, 32 bit processing, sampling rates up to 96kHz, sample rate converters on all the digital inputs, and both EQ and dynamics on every channel. All those tools can be accessed from the control surface, but they can also be controlled from a PC attached to the console via an IP network.

Like most other similar products, Oxygen 4 Digital follows the system architecture of a rack mounted digital 'engine' and a separate 'control surface' with 8 fader.

ENGINE

The 19" rack is the heart of Oxygen 4 Digital. All audio processing and routing takes place in this unit. you can find 4 MIC's, 2 Mono analog and 5 Stereo analog Inputs, 7 Stereo Digital Inputs and Outputs all with sample rate converters. You have dedicated analog outputs for PROG, SUB, AUX, CRM and PHONES. The control surface and DSP engine can be separated

by up to 5 metres using a 15 way D-sub ended cable. Signal processing takes place in one DSP. Processing uses precise floating-point calculations at a word-length of 32 bit. All audio signals throughout the console preserve their 24 bit resolution from the input conversion. Even 16 bit data streams, like CD-players, have 24 bits reserved..



I/O CAPABILITIES

INPUTS

6x stereo Dig inputs (AES3)
 1x stereo dig input (s/p-dif optical or coax)
 6x stereo balanced line inputs
 1x stereo unbalanced line input
 4x balanced mic inputs + Inserts

INPUTS

6x stereo digital outputs AES3
 1x stereo digital output s/p-dif optical + coax
 1x stereo Program analog
 1x stereo SUB analog
 1x stereo CUE analog
 1x stereo AUX analog
 1x stereo CRM analog
 2x stereo PHONES analog

INPUT ROUTER

The audio-paths within Oxygen 4 Digital are programmable due to the presence of an input router. This eliminates the need for an external patch-bay. The input matrix is situated between the input modules and the DSP. It allows a custom configuration of the various inputs into the 4 stereo processing channels.

CONTROL SURFACE

CHANNEL STRIP

Oxygen 4 Digital control surface is divided into two distinct areas on the conventional lines of input and master sections. The input channels comprise eight identical strips.

Starting from the bottom we have a full size fader which obviously controls the level for whatever source is routed to that channel, but in software it can also be configured to perform fader start, red light switching and monitor muting.

Above and to the left of the fader, a group of eight LEDs show status information for that strip. The two larger ones indicate which of the two main output busses the strip is routed to: Programme or Sub. This signal is always post-fade and post the channel's On switch. The 'Sub' buss would usefully provide a stereo clean feed to (for example) external codecs.

The next group of three indicators is dedicated to the aux buss and the assignable EQ and dynamics. The aux buss is stereo and may be selected independently on each channel as a pre or post-fade send. Each Oxygen 4 Digital channel may also be assigned a 'dynamics' control function – a combined compressor-limiter with a single control. The EQ provides 3 bands, each with a range of 2 octaves. The pre-set centre frequencies of 120Hz, 1.2kHz and 12kHz are sensible choices, but they may be changed in software should other values be preferred.

A simple three LED meter is provided on each channel indicating audio levels at -20, 0 and +9dB.

Each strip supports two large illuminated buttons labelled 'On' and 'Cue'. The On button functions pretty much as you would expect, and it may additionally be configured to provide a machine start command.

The Cue button enables a pre-fade listen, and this too may be configured in software for various other functions.

At the top of the channel are the two most obviously digital controls: a single rotary encoder and a 2 line LED alpha display.

The latter shows the currently assigned input on the top line, while various options are displayed on the lower line.

The encoder may be turned or pushed, depending on what function is currently selected. For example, switching to an output buss is achieved by pushing the knob to switch the selected buss routing on or off, whereas setting an input level is a rotary function.



NETWORK OPERATION

Oxygen 4 Digital is a stand-alone mixer.

That means that there is no need for a PC during operation.

But to make all the settings You can connect your console directly to your PC by a cross-link cable or connect your Oxygen 4 Digital to your local network (Straight CAT5 UTP cable) and use its PC interface to communicate with the console.

By using the Ethernet connection you have the possibility to control Oxygen 4 Digital from every workplace in your network.

Oxygen 4 Digital can receive an IP address via a DHCP server, or you can give a Fixed IP ! When this IP is known, you are able to manage the console features by software (HTTP web server or ActiveX object).

MASTER SECTION The right hand master section is topped by a pair of LED level meters, scaled from -36 to +9dB. Below this, two banks of switches cover the function assignment to the channel encoders, and source selection for the monitors. There are also level controls for the monitor speakers and headphones – the latter with a socket on the rear of the control surface.



A memory card slot on the control surface can be used to save desk configurations for instant recall, and individual users may be granted different levels of access to the various desk functions – an excellent solution to situations where ‘finger trouble’ is a problem.

Axel Technology also supplies a couple of programs to help new users get around the desk. The first of these is a simple utility to adjust the channel equalisation.

The second is an Active-X applet that generates a virtual console on your computer screen, showing all of the

desk’s settings and enabling real time adjustments too.

With this utility, it is possible to control the digital engine from any PC connected to the same network as the console.



BLOCK DIAGRAM

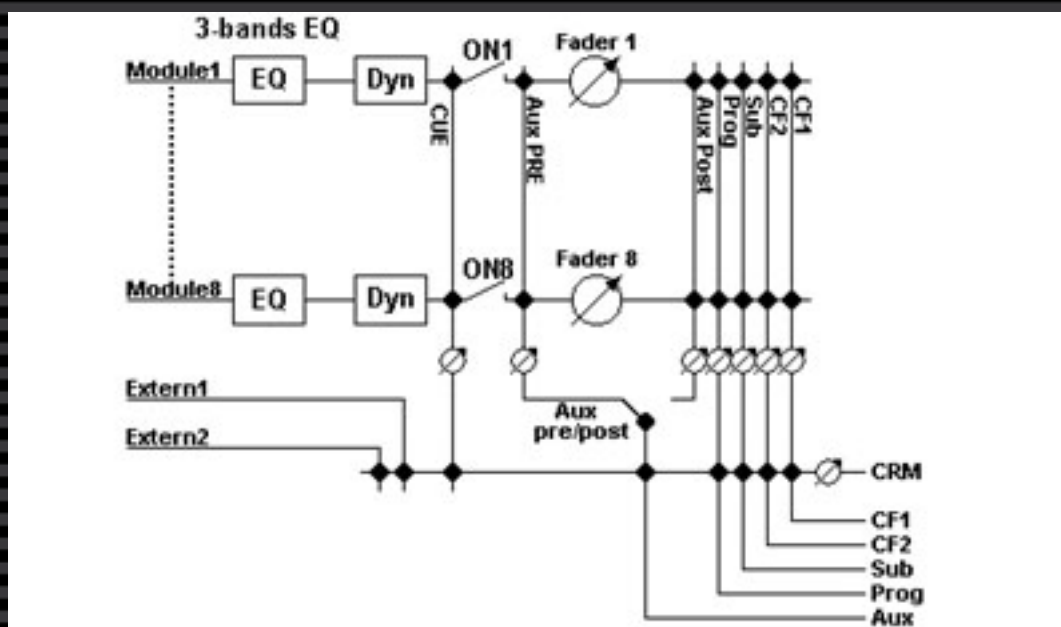

Anzola Emilia - Via Caduti Di Sabbiuno 6/F - 40011 Bologna - Italy
 TEL+39 051 736555 - FAX +39 051 736170
 e-mail: info@axeltechnology.com - web site: www.axeltechnology.com